

SMARTFLOW® Mold Temperature Regulator

Operating Instructions

General

The Smartflow Mold Temperature Regulator controls the temperature of cooling water exiting a mold, thereby regulating the mold temperature.

A mold is heated by the resin shot. The heat from the mold is transferred to the cooling water. The regulator senses the water temperature and restricts the cooling water flow, giving it time to be heated by the mold, until it reaches the desired set point. The regulator valve slowly widens to allow the cooling water to go through at a rate that will hold the mold temperature at a value that corresponds to the set point.

Remember that the mold temperature is always hotter than the cooling water return temperature.

Mode of Operation

When the temperature of the cooling water is greater than the desired set point, the regulator adjusts the valve opening to increase flow. When the cooling water temperature is less than the desired set point, the valve opening closes, decreasing flow. The set point is adjusted with the control knob on the end of the unit. A thermometer provides visual indication of the cooling water temperature.

Since every mold is different, data is not available for every situation. The molder should determine the outgoing coolant temperature, and make adjustments based on experience.

Flushing

The Smartflow Mold Temperature Regulator incorporates a special *flush* feature to remove particles which may become lodged inside. By turning the control knob fully clockwise, the valve is completely open. Any foreign particles should be removed by the increased cooling water flow. After flushing, return the unit to original setting.

Special Notes

Molders are cautioned that the Smartflow regulator will not work for every mold size. Molders making very small parts may not have enough heat from the resin shot to heat the mold adequately.

Generally, the regulator can be used where the cooling water supply is cooler than the water exiting the mold.



Specifications

Regulator

Cooling Water
Set Point Range80° to 120°F
(27° to 49°C)
Accuracy±1°F
Thermometer is not as accurate as the operation of the Mold Temperature Regulator.

Thermometer indicates the coolant temperature

Range0 to 250°F
(-18 to 121°C)
Accuracy±1°F Mid Scale
±2°F Full Scale

Wetted Materials

All wetted parts are Electroless Nickel-Plated Brass & 303 Stainless Steel. O-rings are Buna-N.

CAUTION

Do not allow the water temperature inside the Mold Temperature Regulator to exceed 200°F for more than 30 minutes. Damage to internal parts will result, and warranty will be void.

Burger & Brown
ENGINEERING

4500 E 142nd Street • Grandview, MO 64030 • Tel. (816) 878-6675 • Fax (816) 878-6683 • www.smartflow-usa.com

Form #104 [05.23]

SMARTFLOW®

Smartflow® Mold Temperature Regulator

Installation

NOTE: Flush a newly-installed mold to remove rust and corrosion particles before installing the Mold Temperature Regulator.

Install the regulator as close to the mold as possible to reduce variables affecting the cooling water temperature.

Inlet 1/4" NPT(F)

Outlet 1/2" NPT(F)

1. Connect the water exiting the mold to the 1/4" inlet or manifold ports of the regulator. "IN" is stamped next to the inlet on the regulator body.

Do not over-tighten inlet connection past 7.6mm/0.3" deep!

2. Connect the return circuit to the 1/2" outlet of the regulator. "OUT" is stamped next to the outlet on the regulator body.
3. Move the control knob clockwise until it stops. Turn the control knob counter-clockwise to the 120° mark. Continue turning the control knob counter-clockwise to set the pointer to the desired cooling water temperature on the set point scale.
4. Start the molding process. It may take a few shots to heat the cooling water so the regulator will respond. The graph at right is provided for reference only, your results may vary.

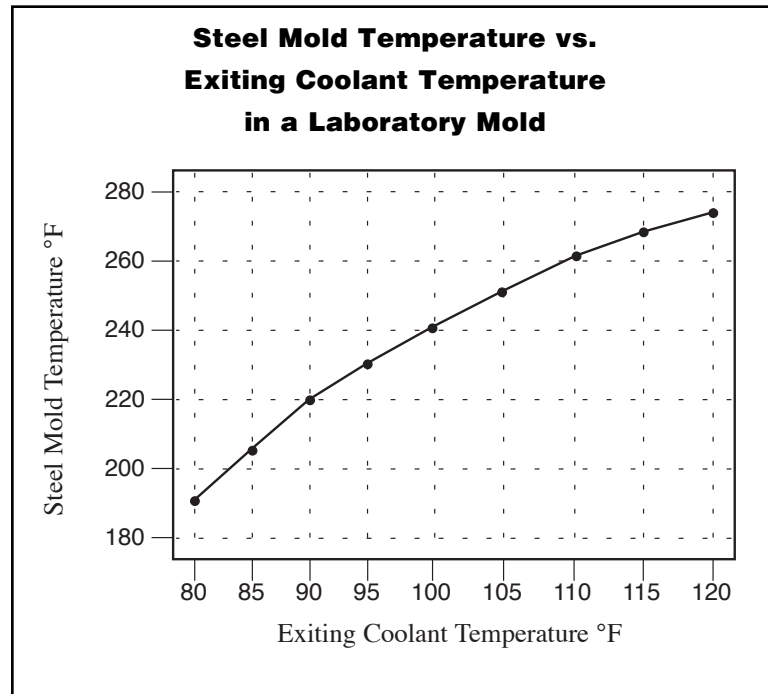

Test Set-up

70°F coolant in @ 50 psi

Heat: 2000 Watt 20 sec on/ 10 sec off

Dimensions

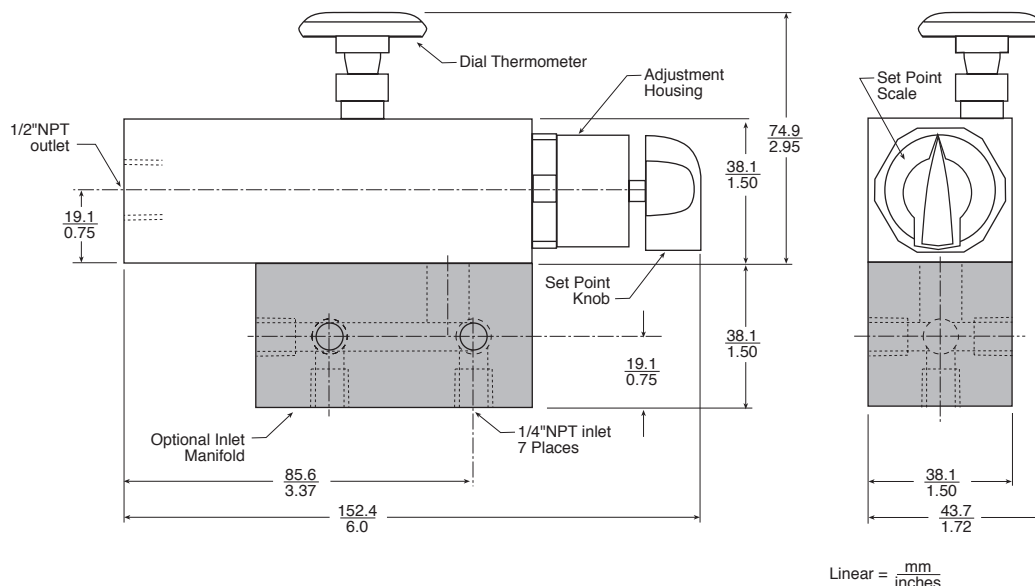

Zone Control Configurations

For single zone control, connect the regulator to the return line from the mold as shown in figure 1.

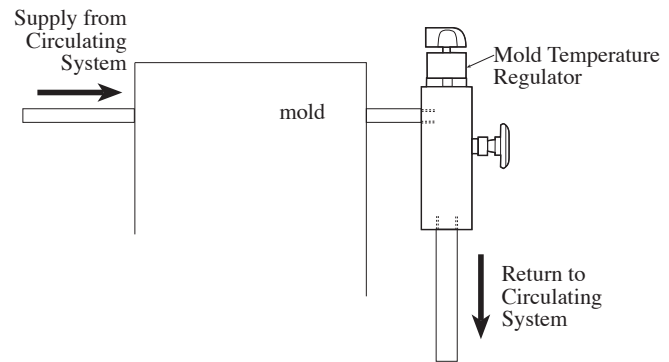

figure 1

To control multiple zones to the same temperature using a single device, connect the lines to the optional manifold of the regulator as shown in figure 2.

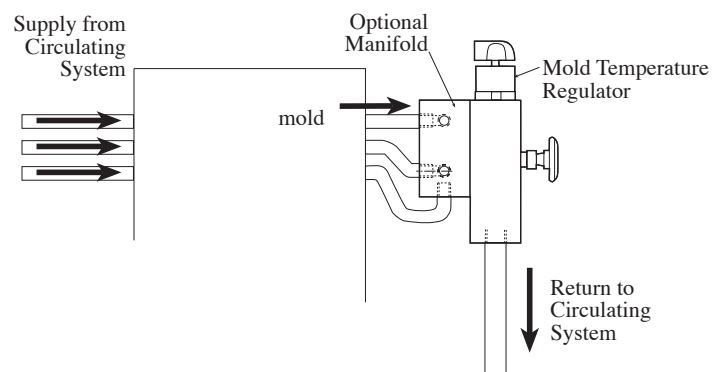

figure 2

To control multiple zones at different temperatures, connect a regulator to each separate zone as shown in figure 3.

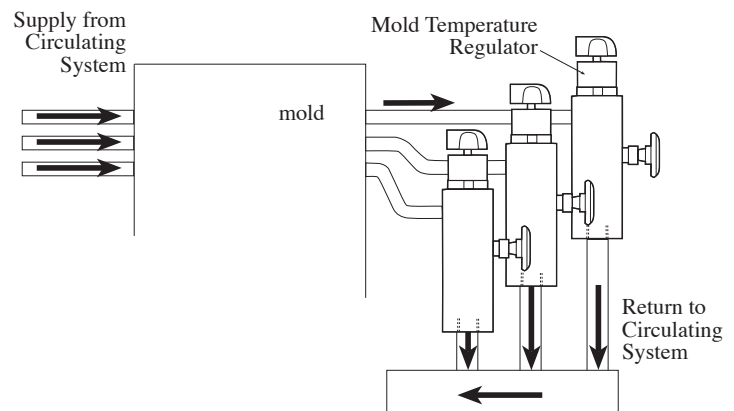

figure 3

Smartflow® Mold Temperature Regulator

Troubleshooting

Symptom	Corrective Action
No flow through the regulator	<ul style="list-style-type: none"> • Check the water supply. • Flush the regulator by turning the control knob fully clockwise to the “flush” position, then reset to desired set point temperature.
Very limited flow through the regulator	<ul style="list-style-type: none"> • Check the installation: water exiting the mold should be connected to the inlet port on the side of the unit. • Cooling water is too cold or there is not enough heat in the mold, add more circuits to the inlet using the optional manifold. See figure 2.
The mold is running too hot	<ul style="list-style-type: none"> • Flush the regulator by turning the control knob fully clockwise to the “flush” position, then reset to desired set point temperature. • There is too much heat in the mold, separate the circuits (if using a manifold), use one regulator per cooling line. See figure 3.
<p>If corrective action fails to correct the problem, please contact the factory.</p>	

Limited Warranty

The limited warranty is void if the Mold Temperature Regulator is disassembled in the field. Return to the factory for re-conditioning if flushing is insufficient to clear particles from the inside.

Seller warrants that this product supplied will conform to the description herein stated and that the product will be of standard quality. This is the sole warranty made by Seller with respect to this product. Seller expressly disclaims any other express or implied warranties, including, but not limited to, the implied warranty of merchantability and the implied warranty of fitness for a particular purpose.

Seller shall not be liable for any cost or damages, whether direct, incidental or consequential, including, but not limited to, any injury, loss or damage resulting from the use of this product, regardless of whether any claim for such cost or damages is based on warranty, contract, negligence, tort or strict liability. The sole liability of Seller is limited to repairing or replacing this product.

This warranty shall not apply to any products that have been repaired or altered by anyone other than Seller. The warranty shall not apply to any products subject to misuse due to common negligence or accident, nor to any products manufactured by Seller which are not installed or operated in accordance with the printed instructions of Seller or which have been operated beyond the rated capacity of the goods. Seller states that the product’s useful safe life is 5 years. Actual life may vary widely depending on operating environment such as temperature, pressure, and chemical exposure.

burger & brown engineering
tel. 800-764-3518 fax 816-878-6683