

TRACER[®] VMA with AutoReg[™] Flow Regulator

(patent pending)

General Description

Tracer_{VMA} with AutoReg Flow Regulator automatically adjusts flow rate to the required user-selected volume regardless of changes in line pressure. This results in a more consistent flow rate with more control over cooling water conditions in critical molding situations.

The User Interface communicates with the valve actuator that automatically adjusts the opening of the internal needle valve of the Delta-Q[®] or brass flow regulator to maintain the correct flow rate or Reynolds Number.

Local or Remote User Interface control allows for convenient installation. User Interface may be mounted up to 2.9M (9.5ft) away from the flow sensor and regulator assembly.

Separate Analog Outputs facilitate data collection of temperature and flow rates. The voltage outputs are user-selectable using on-screen menus: 0 to 3.5/4.1 Volts, 0 to 5 Volts or 0 to 10 Volts.

FCI (Fluid Characteristic Indicator) Technology helps optimize systemic water usage. "TF" on the digital display signifies the presence of Turbulent Flow, or optimum cooling water efficiency. 0, 10, 20 or 30% glycol mix is supported in Turbulent Flow calculations.

SPDT Switch is programmable for one to four set points: low flow, high flow, low temperature, high temperature or turbulent flow condition. Set points may be turned on or off in any combination to signify an alarm state. The switch may be connected to machine controls or a visual indicator such as a low voltage stack light.

Actuator Alarm notifies the user if the Tracer_{VMA} with AutoReg is unable to maintain minimum required flow rate or Reynolds Number. The time interval is programmable.

English or Metric units for flow and temperature can be changed at any time.

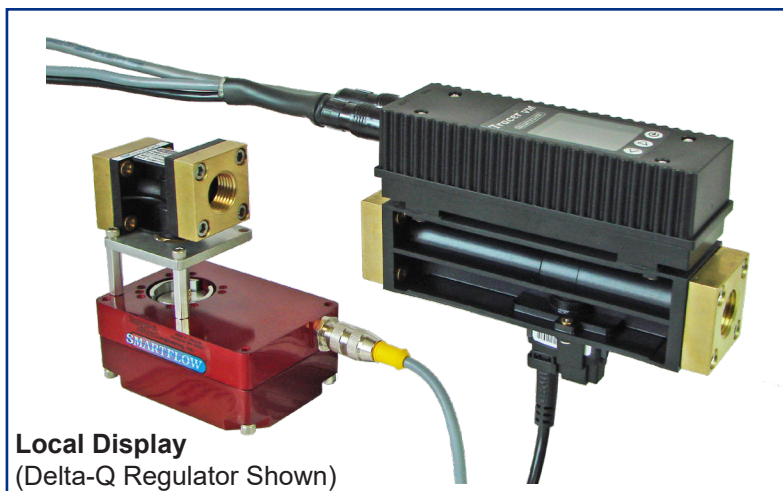

Local Display
(Delta-Q Regulator Shown)

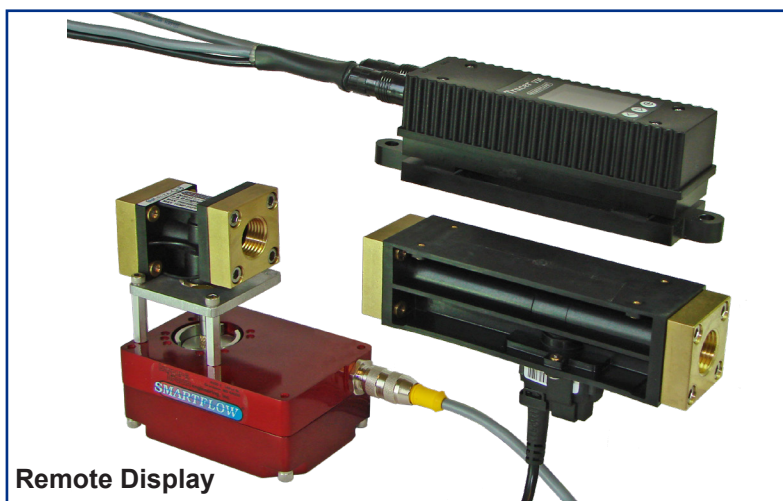

Remote Display

Totalizer Function provides volume display from a user-selected start point which is re-settable at any time. (Maximum value is approximately 42,949,000 liters or 11,338,000 gallons.)

24VDC, 1.5A Power Source with earth ground is required to supply the Tracer_{VMA} AutoReg Flow Regulator.

Actuator may be rotated as a unit in relation to the regulator for ease of installation and accessibility.

Corrosion Resistant Materials are standard. 3/8" and 1/2" options include Delta-Q flow regulator. 3/4" and 1" flow regulator sizes are brass only.

SMARTFLOW® *Tracer*®_{VMA} *Flowmeter*
with *AutoReg*™

Specification

Flow Ranges				
Body Size	Range (LPM)	Range (GPM)	Reynolds Number Deadband	Flow Rate Deadband
3/8" & 1/2"	1 to 18	.3 to 4.8	300	0.1LPM
3/8" & 1/2"	2 to 40	.5 to 10.6	300	0.1LPM
3/4" & 1"	5 to 100	1.3 to 26.4	1000	1.0LPM
1"	10 to 200	2.6 to 52.8	1000	2.0LPM

Flow Accuracy±1.5% of Full Scale
 Temperature Range..... 0°C to 120°C
 (32°F to 248°F)
 Temperature Accuracy±2°C
 Operating Pressure 10.3 bar max.
 (150 psi max.)

Power

Power Supply 24 VDC (external)
 Switch Rating 1A, 30 VDC/30VAC
 Flow and Temp Signals 0 to 5 or 0 to 10 VDC

Materials

Sensing Element Silicone-Based MEMS Sensor
 Seal (sensor to housing)..... EPDM
 Flowmeter Insert..... PPA 40 GF

Flow Body

3/8" & 1/2" Body Size Glass-Filled Nylon Flow Body with
 Brass or Nylon End Caps
 3/4" & 1" Body Size Anodized Aluminum
 or Stainless Steel Flow Body

Flow Regulator

3/8" & 1/2" Delta-Q..... Brass or Glass-Filled Nylon End Caps
 Glass-Filled Nylon
 Stainless Steel Stem and Valve Seat
 EPDM O-Rings
 3/8" BrassBrass Body
 Brass Stem and Valve Seat
 EPDM O-Rings
 3/4" & 1"Brass Body
 Brass Stem and Valve Seat
 EPDM O-Rings

Applications

Tracer_{VMA} with AutoReg Flow Regulator is designed to maintain steady flow rate where pressure fluctuations may adversely impact cooling water conditions. Upstream changes in cooling water pressure can cause unexpected increase or decrease in system pressure, changing the volume of flow. The Tracer_{VMA} AutoReg compensates for these changes by adjusting the flow rate automatically according to user settings.

Menu selections on the User Interface allow input of a target Reynolds Number to maintain Turbulent Flow. The flow rate is automatically adjusted by the controller based on water temperature, flow rate, glycol content and the size of the flow path.

The Tracer_{VMA} AutoReg is ideally suited for use in "lights out" injection molding or where cooling water conditions must be monitored for quality control and process validation.

Tracer_{VMA} AutoReg Flow Regulator can be connected to data acquisition systems providing manufacturers real-time statistical process temperature and flow data.

Annual calibration is recommended for best results. Flow sensor, user interface electronics and valve actuator are matched and must be used together once calibration is complete.

Directives

Flow sensors are in conformity with these Council directives on the approximation of the laws of the EC member states:

- Low Voltage Directive (2006/95/ED)
Standards used: EN 61010-1:2001
- EMC Directive (2004/108/EC)
Standards used: EN 61326-1:2006 and 61326-2-3:2006

Smartflow Vortex flow sensors fall under Article 3, 3 of PED Directive 97/23/EEC and are therefore not required to be CE-marked according to this directive.

SMARTFLOW® *Tracer*® *VMA Flowmeter*
with *AutoReg*™

Model Number

VMA 3 - B - 18H - L - QA3 - P1				
Body Size				Optional Pressure Gauges (Located on User Interface) P1 30 psi Pressure Gauge P2 60 psi Pressure Gauge P3 100 psi Pressure Gauge P4 160 psi Pressure Gauge (Pressure gauges not available with AL body material)
3/8"NPT	3	B or N	18H	
3/8"BSPP	3B			
1/2"NPT	4			
1/2"BSPP	4B			
3/4"NPT	6	AL or SS	100H	
3/4"BSPP	6B			
1"NPT	8	AL or SS	100H	
1"BSPP	8B			
				Flow Regulator with Actuator (match to User Interface size) QA3 3/8"NPT Delta-Q Precision Flow Regulator QA3B 3/8"BSPP Delta-Q Precision Flow Regulator QA4 1/2"NPT Delta-Q Precision Flow Regulator QA4B 1/2"BSPP Delta-Q Precision Flow Regulator FR3 3/8"NPT Brass Flow Regulator FR3B 3/8"BSPP Brass Flow Regulator FR6 3/4"NPT Brass Flow Regulator FR6B 3/4"BSPP Brass Flow Regulator FR8 1"NPT Brass Flow Regulator FR8B 1"BSPP Brass Flow Regulator
Body Material				
Glass-Filled Nylon with Brass End Caps Nylon End Caps (3/8" and 1/2" only)		B N		
Anodized Aluminum Stainless Steel (3/4" and larger only)		AL SS		
	Flow Range			
	1 to 18 LPM (.3 to 4.8 GPM)		18H	
	2 to 40 LPM (.5 to 10.6 GPM)		40H	
	5 to 100 LPM (1.3 to 26.4 GPM)		100H	
	10 to 200 LPM (2.6 to 52.8 GPM)		200H	

3/8" or 1/2" User Interface & Flow Body

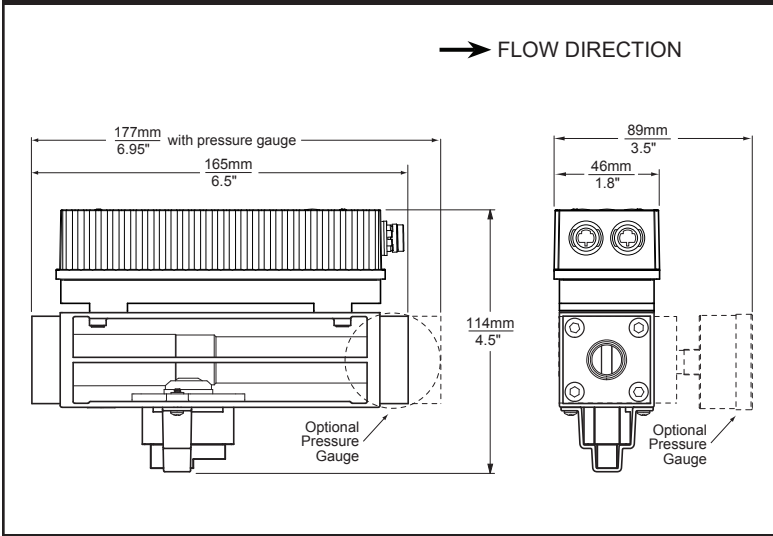

Regulator with Actuator (3/8" & 1/2" Delta-Q®)

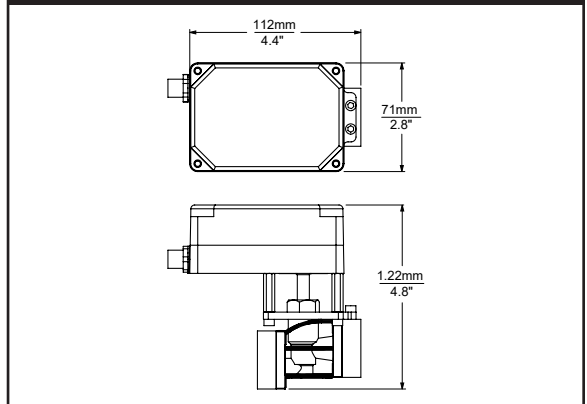

3/4" & 1" User Interface & Flow Body
Aluminum or Stainless Steel
(pressure gauge not available with AL body)

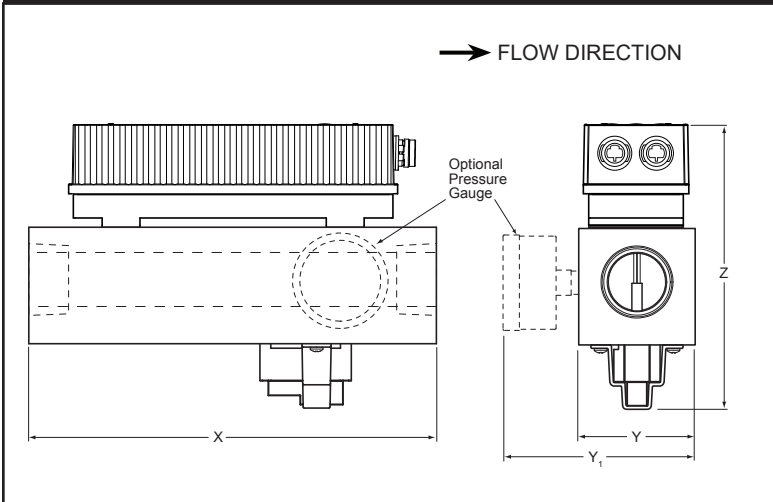

Regulator with Actuator (3/8" Brass)

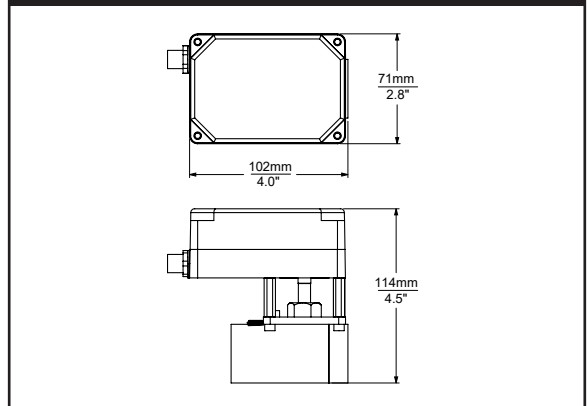

Regulator with Actuator (3/4" & 1" Brass)

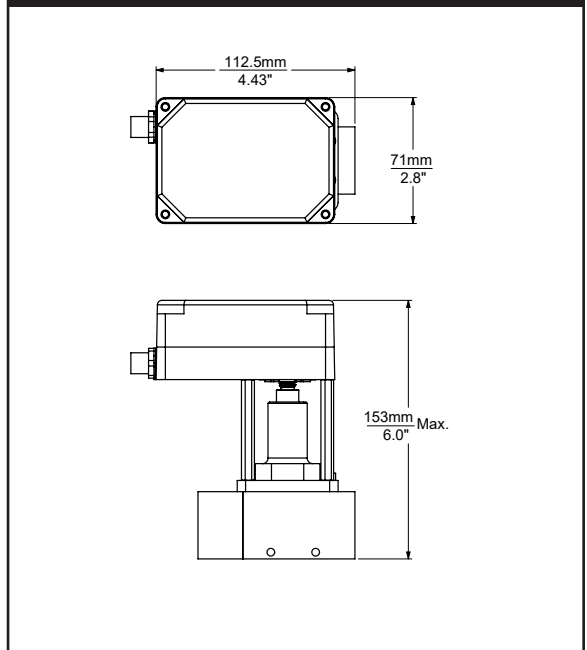

Dimensions (mm/inches)

Body Size	X	Y	Y ₁	Z
3/4", 5 to 100 LPM	178/7.0	45.7/1.8	77/3.1	117/4.6
1", 5 to 100 LPM	178/7.0	45.7/1.8	77/3.1	117/4.6
1", 10 to 200 LPM	178/7.0	51/2.0	84/3.3	122/4.8



4500 E 142nd Street ♦ Grandview, MO 64030 USA
Tel: 816-878-6675 ♦ Fax: 816-878-6680
www.smartflow-usa.com